



US Army Corps
of Engineers®
St. Paul District

Flood-Fight Handbook



Preparing For a Flood

Flood-Fight Handbook - Preparing for a Flood

Table of Contents

1	<i>Steps to Reduce Flood and Water Damage in Homes and Businesses</i>	1
1.1	<i>Home & Business Preparedness</i>	1
1.2	<i>Family Preparedness</i>	3
2	<i>Sandbagging for Flood Protection</i>	4
2.1	<i>Site Selection</i>	4
2.2	<i>Stacking Sandbags to Form a Dike</i>	5
2.3	<i>Sealing the Dike</i>	6
2.4	<i>Amount of Sandbags Needed</i>	7
3	<i>Earth Fill Levees</i>	8
3.1	<i>Foundation Preparation</i>	8
3.2	<i>Levee Fill</i>	8
3.3	<i>Levee Design Section</i>	9
3.4	<i>Scour Protection for Emergency Levees</i>	10
4	<i>Interior Drainage Treatment</i>	12
4.1	<i>General</i>	12
4.2	<i>Preliminary Work</i>	12
4.3	<i>Determination of Pumping Requirements</i>	12
4.4	<i>Pumps: Types, Sizes and Capacities</i>	15
4.5	<i>Metal Culverts</i>	18
4.6	<i>Preventing Backflow in Sewer Lines</i>	19

5	<i>Flood Fight Problems</i>	20
5.1	<i>General</i>	20
5.2	<i>Overtopping</i>	20
5.3	<i>Seepage</i>	20
5.4	<i>Sand Boils</i>	21
5.5	<i>Erosion</i>	22
5.6	<i>Storm and Sanitary Sewers</i>	22
5.7	<i>Closures</i>	22
5.8	<i>Causes of Levee Failure</i>	23
6	<i>Recommended Techniques for Flood Fighting Activities</i>	24
	<i>PLATE 1: Recommended Method for Sandbag Levee Construction</i>	
	<i>PLATE 2: Recommended Method for Flashboard or Box Levees</i>	
	<i>PLATE 3: Recommended Method for Placement of Polyethylene Sheeting on Temporary Levees (when placed in the dry)</i>	
	<i>PLATE 4: Recommended Method for Placement of Polyethylene Sheeting on Temporary Levees (when placed in the wet)</i>	
	<i>PLATE 5: Recommended Method for Ringing Sand Boils</i>	
	<i>PLATE 6: Recommended Method for Adapting Manhole for Pumping, Method 1</i>	
	<i>PLATE 7: Recommended Method for Adapting Manhole for Pumping, Method 2</i>	
	<i>PLATE 8: Recommended Method for Plugging Pipes, Method 1</i>	
	<i>PLATE 9: Recommended Method for Plugging Pipes, Method 2</i>	

Links to sources of information provided herein as well as to other useful websites:

North Dakota State University, Extension Service, Coping With Floods website at:
<http://www.ag.ndsu.nodak.edu/flood/home.htm#prepare>

Dane County, Wisconsin, Department of Emergency Management website at:
<http://www.countyofdane.com/ems/floodsafety.htm>

American Red Cross, Flood & Flash Flood Preparedness website at:
http://www.redcross.org/services/disaster/0,1082,0_585_,00.html

1 Steps to Reduce Flood and Water Damage in Homes and Businesses

The following section is copied from the North Dakota State University, Extension Service, Coping With Floods website at: <http://www.ag.ndsu.nodak.edu/flood/home.htm#prepare>.

Many things can be done before the snow melts or before a heavy rainstorm to reduce damage to home and property. This checklist can help you prepare to reduce the severity of water or a flood on your home and family.

1.1 Home & Business Preparedness

Check your sump pump.

Clean the sump pump and pit, and test the pump by pouring water into the pit. Consider having a spare submersible portable sump pump. Make sure the discharge hose delivers the water several feet away from the house to a well-drained area that slopes away from the house. If the hose outlet is too close to the house foundation or on flat ground, the water may simply recycle down through the house drain tile. Don't run sump pump water into a rural septic system because the water may saturate the drain field. In cities, running sump pump water into the sanitary system may overload the system and cause sewage backup. Such actions may also be illegal.

Move valuables to higher locations.

Get items such as irreplaceable family photo albums, high school yearbooks, personal videotapes, tax records, insurance policies and household inventories off the bottom shelves in the lower level of your home.

Plug basement floor drains with removable grids.

A flexible rubber ball about 1-¼ times the inside diameter of the pipe can be wedged into the drain to create a tight seal. The pressure might be quite high so brace the ball securely with a 2 by 4 against the ceiling. Hold a board or piece of plywood on the ceiling and slide the 2 by 4 against the bottom of the board to avoid damage to plaster ceilings. For a suspended tile ceiling, remove ceiling tiles to get access to the ceiling joists. Span a 2 by 4 across the two joists and wedge the vertical 2 by 4 between it and the ball. Some hardware stores sell a plug that has a rubber center that expands to fill the pipe when the top and bottom metal plates are squeezed.

Cover basement floor drains with permanent grids.

Place a partially inflated inner tube around the drain, and top it with a square or two of plywood (not particle board). The plywood must be larger across than the inner tube to cover it. Brace this in place just as with the ball on the drain. Be prepared for some seepage.

-
- Reduce flooding from other drains.**

Unbolt toilets from the floor and plug the outlet pipes using the same procedure as for floor drains. Shower drains can be plugged this way too. Most washing machines and basement sinks have their drain connections about 3 feet above the floor so they may not overflow if the water doesn't get that high. If necessary, these drains can be disconnected and capped or plugged with braced rubber balls.
 - Move snow away from the house's foundation.**

If the ground is sloped 1 inch per foot near the house, moving snow just 3 to 5 feet from the house will reduce problems.
 - Keep water out of window wells.**

Because windows can't withstand much pressure, build dams and contour the ground so water will naturally drain away from the house.
 - Get downspouts down in place.**

As the snow melts, downspouts can carry the water away from the house. Using salt or a chemical to melt them free will probably damage the lawn.
 - Prepare appliances for flooding.**

Shut off appliances at the fuse box or breaker panel. Put freezers, washer, dryers and other appliances up on wood or cement blocks to keep the motors above the water level. If high water is imminent and large appliances can't be moved, wrap them in polyethylene film, tying the film in place with cord or rope. The water will still get in, but most of the silt won't so cleanup will be easier.
 - Shut off electricity to areas of the home that might flood.**

Even if floodwaters are not reaching electrical outlets, the risk of electrical shock to someone working in a flooded basement is high with electric motors in the furnace, freezer, washer, dryer and other appliances. Shut off electrical breakers or unscrew fuses. Don't stand in water and turn off electrical switches. If this must be done, use a dry piece of wood or a plastic or rubber pole to do the switching, and stand on a block of wood or a plastic crate that doesn't conduct electricity. If floodwaters are getting close to the electrical entrance box, call the power supplier and have the electrical supply to the house disconnected. If the floor is damp but not really flooded, ground fault circuit interrupters reduce the risk of using electricity. In newer homes, interrupters can be identified by the buttons between the top and bottom outlets. They can be added to any outlet or in an extension cord to turn off the power if there's danger of water.
 - Move hazardous materials to higher locations.**

This includes paint, oil, cleaning supplies and other dangerous materials.
 - Plan an escape route.**

If certain roads or streets are known to flood easily, where would you go if your home flooded? Possibilities include a local shelter or a family member or friend's house.
-

- Plan for pets.**
Make plans for the care of your pets in the event of a flood. Pets aren't allowed in shelters due to health regulations. Leaving a pet at home during an evacuation may result in a threat to its safety. Also, stressed pets can damage your home.
- Assemble supplies in case the electricity goes off.**
Gather water, food that requires no refrigeration or cooking, a non-electric can opener, a battery-powered radio and flashlight, and extra batteries.
- Assemble supplies for a possible evacuation.**
Gather water, nonperishable food, paper plates/cups and plastic utensils, extra clothing and shoes, blankets or sleeping bags, a first aid kit and prescription medications, cash and credit cards, important phone numbers, special items for babies and the elderly.

1.2 Family Preparedness

- Discuss what to do in case of a flood.**
Plan and practice an evacuation route.
- Ask an out-of-state family member or friend to be your family contact.**
If family members get separated during an evacuation, each should get in touch with that contact. Make sure everyone has the contact's phone numbers.
- Discuss safe emergency procedures.**
Teach adults and older children where electric fuse boxes, water service mains and natural gas mains are and how to turn them off if necessary.
- Discuss the situation with children honestly and openly.**
Hiding the situation from them will probably be even more stressful.

2 Sandbagging for Flood Protection

The following section is copied from several sources, in particular: 1) the North Dakota State University, Extension Service, *Coping With Floods* website at: <http://www.ag.ndsu.nodak.edu/flood/home.htm#prepare> and 2) the Dane County, Wisconsin, Department of Emergency Management website at: <http://www.countyofdane.com/ems/floodsafety.htm>. Some information is from the St. Paul District U.S. Army Corps of Engineers.

A properly built sandbag dike can prevent or reduce flood damage.

Bags must be filled and placed properly to give the best protection. Any available material can be used to fill sandbags, but sand is easiest to handle. Silt and clay will form a good dike but are more difficult to work with. Different size bags are available, but bags are easier to handle if weight is limited between 35 and 40 pounds. This weight limit is particularly important when teenagers or older persons will be handling the bags.

Typically sandbags are filled approximately half full and do not need to be tied. It is desired that the sandbag lay flat when put into place. Overfilled bags leave gaps in the dike, allowing water to seep through.

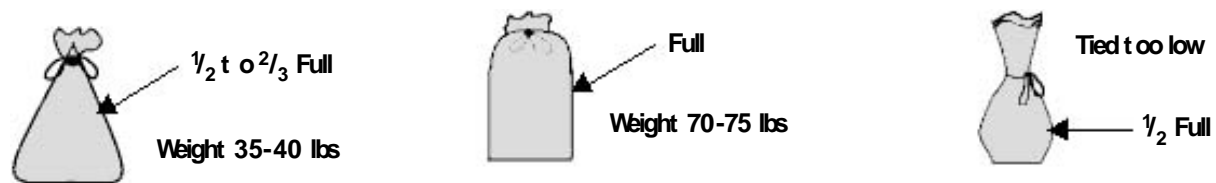

The drawings on the following pages illustrate a number of suggested techniques for using sandbags and other materials to build temporary flood protection measures.

Contact your county emergency office for information on where to obtain sandbags.

2.1 Site Selection

Select the location for the dike taking advantage of natural land features that keep the dike as short and low as possible. Avoid any obstructions that would weaken the dike. Do not build the dike against a building wall. Leave about 8 feet to maneuver between the dike and buildings. Remove all ice and snow from a strip of land at least as wide as the base of the dike. If the dike is to be more than about 3 feet high, remove a strip of sod to provide better anchorage for the dike.

2.2 Stacking Sandbags to Form a Dike

Overlap the sandbags as shown in *Figure 2*, placing the first layer of bags lengthwise of the dike and lapping the bags so the filled portion of one bag lies on the unfilled portion of the next. The base of the dike should be three times as wide as the dike is high, as shown in *Figure 3*. The second layer of bags should be perpendicular to the first layer, then alternate direction of the bags to the top of the dike, as shown in the “Correct” example in *Figure 4*.

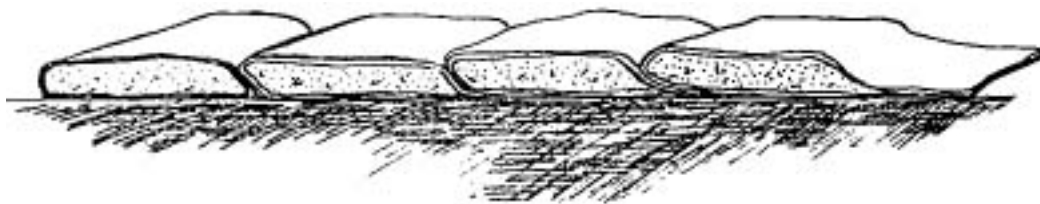

Figure 1

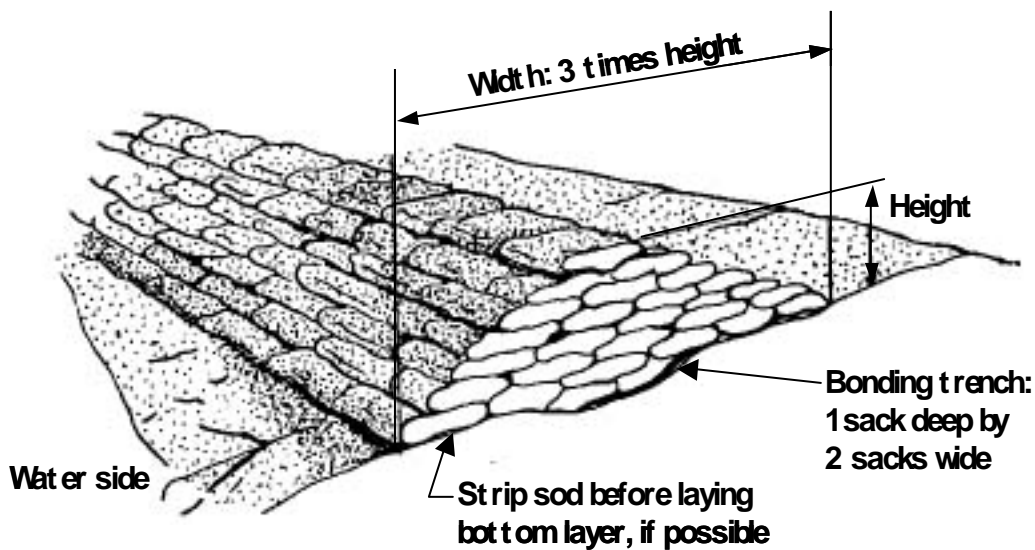

Figure 2

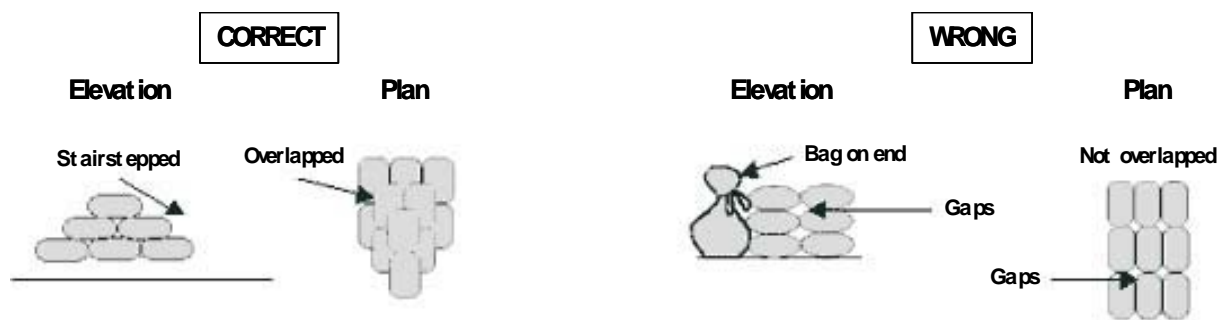

Figure 3

2.3 Sealing the Dike

The finished dike can be sealed with a sheet of polyethylene plastic to improve water tightness. Spread a layer of dirt or sand 1 inch deep and about 1 foot wide along the bottom of the dike on the water side. Lay the poly sheeting so the bottom extends 1 foot beyond the bottom edge of the dike over the loose dirt. The upper edge should extend over the top of the dike. The sheeting should be about 6 mils thick. It is generally available in 20-foot-wide by 100-foot-long rolls from construction supply firms, lumberyards, and farm stores.

Starting at the downstream end of the dike lay the poly sheeting down very loosely. The pressure of the water will then make the poly conform easily to the sandbag surface. If the poly is stretched too tightly the water force could puncture it.

As shown in *Figure 5*, place a row of sandbags on the bottom edges and top edges of the poly to form a watertight seal along the water side.

Figure 6 illustrates how the poly should be placed on the downstream portion of the dike first, then worked upstream with 3-foot to 5-foot overlaps between sheets of poly.

Place sandbags, boards, or dirt between the bags to prevent winds from disturbing the poly. Avoid puncturing the poly with sharp objects or by walking on it.

Plate 3 and *Plate 4* illustrate additional details for securing the poly over temporary dikes and levees.

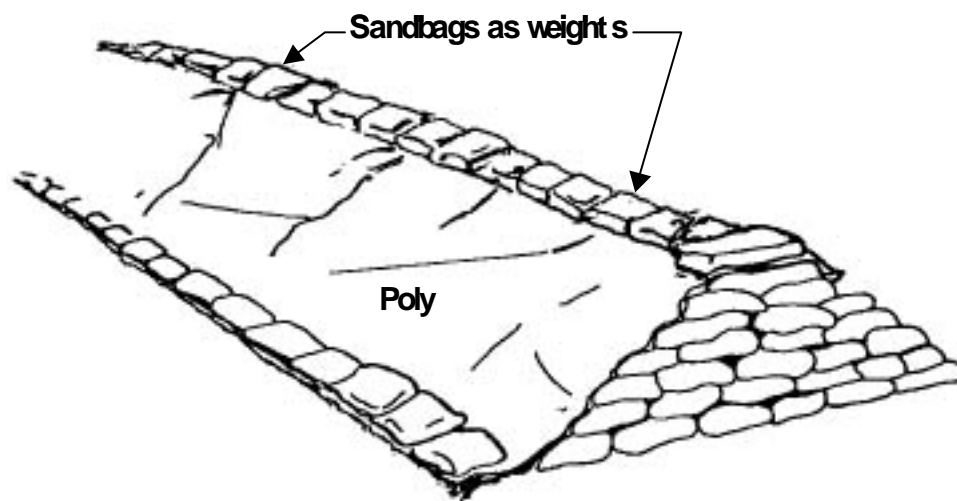

Figure 4

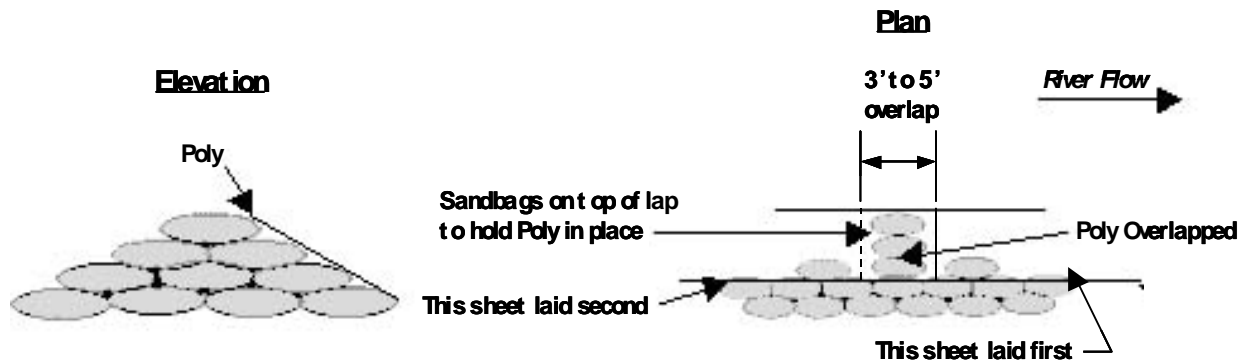

Figure 5

2.4 Amount of Sandbags Needed

The following tables indicate the approximate number of sandbags that are need for dikes of various heights. Note that 5 feet is the practical limit of a sandbag dike. If a higher dike is needed, alternative means of construction should be considered. The preferred limit for dike height is 3 feet.

ESTIMATED NUMBER OF SANDBAGS PER LINEAR FOOT OF DIKE	
Height in Feet	Bags Required
1	5
2	10
3	21
4	36
5	55

DIKE HEIGHT	NUMBER OF SANDBAGS REQUIRED FOR LENGTH OF DIKE									
	50 FT	100 FT	175 FT	200 FT	250 FT	300 FT	350 FT	400 FT	450 FT	500 FT
1 Foot	250	500	750	1,000	1,250	1,500	1,750	2,000	2,250	2,500
2 Feet	850	1700	2,550	3,400	4,250	5,100	5,950	6,800	7,650	8,500
3 Feet	1,800	3,600	5,400	7,200	9,000	10,800	12,600	14,400	16,200	18,000
4 Feet	3,100	6,200	9,300	12,400	15,500	18,600	21,700	24,800	27,900	31,000

3 Earth Fill Levees

Earth fill levees are the preferred type of emergency flood barrier for large scale flood fights.

3.1 Foundation Preparation

Prepare levee footprint prior to placing fill. Remove snow from ground surface. Place snow on riverside of levee to eliminate ponding of water behind levee when snow melts. Trees should be cut and the stumps removed. All obstructions above the ground surface should be removed, if possible. This will include brush, structures, snags, and similar debris. The foundation should then be stripped of topsoil and surface humus. *NOTE: Clearing and grubbing, structure removal and stripping should be performed only if time permits.* Stripping may be impossible if the ground is frozen; in this case, the foundation should be ripped or scarified, if possible, to provide a tough surface for bond with the embankment. Every effort should be made to remove all ice or soil containing any ice lenses. Frost or frozen ground can give a false sense of security in the early stages of a flood fight. It can act as a rigid boundary and support the levee; however, on thawing, soil strength may be reduced sufficiently for cracking or development of slides. It also forms an impervious barrier to prevent seepage. This may result in a considerable build up in pressure under the soils landward of the levee, and, upon thawing, pressure may be sufficient to cause sudden blowouts. If this condition exists, it must be monitored, and one must be prepared to act quickly if sliding or boiling starts. If stripping is possible, the material should be pushed landward and riverward of the toe of levee and windrowed. After the flood, this material can be spread on the slopes to provide topsoil for vegetation.

3.2 Levee Fill

Earth fill materials for emergency levees will come from local borrow areas. An attempt should be made to use materials that are compatible with the foundation materials as explained below. However, due to time limitation, any local materials may be used if reasonable construction procedures are followed. The materials should not contain large frozen pieces of earth.

1. **Clay Fill.** The majority of earth fill levees erected in recent floods consisted of clay or predominantly clayey materials. Clay is preferred because the section can be made smaller (steeper side slopes). Also, clay is relatively impervious and has relatively high resistance to erosion in a compacted state. A disadvantage in using clay is that adequate compaction is difficult to obtain without proper equipment. Another disadvantage is that the clay may be wet and subfreezing temperatures may cause the material to freeze in the borrow pit and in the hauling equipment. Weather could cause delays and should definitely be considered in the overall construction effort.
2. **Sand Fill.** If sand is used, the section should comply as closely as possible with recommendations in the following paragraphs. Flat slopes are important, as steep slopes without poly coverage will cause seepage through the levee to outcrop high on the landward slope and may cause slumping of the slope.

3. **Silt.** Material that is primarily silt should be avoided, and, if used, poly facing must be applied to the river slope. Silt, upon wetting, tends to collapse under its own weight and is very susceptible to erosion.

3.3 Levee Design Section

The levee design section is generally dictated by the foundation soils and the materials available for construction. Therefore, even under emergency conditions, an attempt should be made to make the embankment compatible with the foundation. Information on foundation soils, if available from local officials or engineers, should be used. The three foundation conditions and the levee sections cited below are classical and idealized. Usual field conditions depart from them to various degrees. However, they should be used as a guide so that possible serious flood fight problems might be lessened during high water. In determining the top width of any type of section, consideration should be given as to whether a revised forecast will require additional fill to be placed. A top width adequate for construction equipment will facilitate raising the levee. Finally, actual dike construction will, in cases, depend on time, materials, and right-of-way available.

1. **Sand Foundation** → Pervious (readily allowing water to pass through).
 - a. **Sand Section.** Use 1V (Vertical) on 3H (Horizontal) river slopes, 1V on 5H landward slope, and 10-foot top width.
 - b. **Clay Section.** Use 1V on 2- $\frac{1}{2}$ H for both slopes. Bottom width should comply with creep ratio criterion; i.e., L (across bottom) should be equal to C x H; where C=9 for fine gravel and 15 for fine sand in the foundation, and H is levee height. This criterion can be met by using berms either landward or riverward of the levee. Berm thickness should be 3 feet or greater. Berms are used mainly to control or to relieve uplift pressures and will not reduce seepage significantly.
2. **Clay Foundations** → Impervious
 - a. **Sand Section.** Same as paragraph a. above.
 - b. **Clay Section.** Use 1V on 2- $\frac{1}{2}$ H for both slopes.
3. **Clay Layer over Sand Foundation**
 - a. **Sand Section.** Use same design as paragraph a. above. In addition, a landside berm of sufficient thickness may be necessary to prevent rupture of the clay layer. The berm may be composed of sand, gravel, or clay material. Standard design of berms requires considerable information and detailed analysis of soil conditions. However, prior technical assistance may reduce berm construction requirements in any emergency situation.
 - b. **Clay Section.** Use same design as paragraph b. above, "Clay Section," except a berm to prevent rupture may be necessary.

Proper compaction of the emergency levee is critical to stability. Use of standard compaction equipment, such as a sheepsfoot roller, during emergency operations may not be feasible because of time constraints. It is expected in most cases that the only compaction will be from hauling and spreading equipment, such as dump trucks and dozers.

3.4 Scour Protection for Emergency Levees

Scour protection may be required for the emergency levees. Factors that influence whether or not additional scour protection is required include levee material (clay levees tend to be much more resistant to scour than sand levees), channel velocities, presence of ice and /or debris in channel, wave action, and seepage. Methods of protecting levee slopes are numerous and varied. However, during a flood emergency, time, availability of materials, cost and construction capability preclude the use of all accepted methods of permanent slope protection. Field personnel must decide the type and extent of slope protection the emergency levee will need. Several methods of protection have been established that prove highly effective in an emergency. Again, resourcefulness on the part of the field personnel may be necessary for success. The following is a brief summary of some of the options for providing emergency scour protection for levees.

- 1. Polyethylene and sandbags.** A combination of polyethylene (poly) and sandbags has proven to be one of the most expedient, effective and economical methods of combating slope attack in a flood situation. Poly and sandbags can be used in a variety of combinations, and time becomes the factor that may determine which combination to use. Ideally, poly and sandbag protection should be placed in the dry. However, many cases of unexpected slope attack will occur during high water, and a method for placement in the wet is covered below. **Plate 3** and **Plate 4**, respectively, display suggested methods of laying poly and sandbags in the dry and in the wet. Because each flood fight project is unique (river, personnel available, materials, etc.), specific details of placement and materials handling will not be covered. Field personnel must be aware of resources available when using poly and sandbags.

Anchoring the poly along the riverward toe is important for a successful job. It may be done in three different ways: 1) A trench is excavated along the toe of the levee, poly is placed in the trench, and the trench is backfilled; 2) Poly is placed flat on the ground surface away from the levee toe, and earth is pushed over the flap; 3) Poly is placed flat on the ground surface away from the levee toe and one or more rows of sandbags placed over the flap. The poly is then unrolled up the slope and over the top enough to allow for anchoring with sandbags. Poly should be placed from downstream to upstream along the slopes and overlapped at least two feet. The poly is now ready for the "hold down" sandbags.

It is mandatory that poly placed on levee slopes be held down. Unless extremely high velocities, heavy debris, or a large amount of ice is anticipated, an effective method of anchoring poly is a grid system of sandbags. A grid system can be constructed faster and requires fewer bags and much less labor than a total covering. Various grid systems include vertical rows of lapped bags, 2 by 4 lumber held down by attached bags, and rows of bags held by a continuous rope tied to each bag. Poly has been held down by a system using two bags tied with rope and the rope saddled over the levee crown with a bag on each slope. For more the more extreme conditions mentioned previously, a solid blanket of bags over the poly should be used. **Plate 3** and **Plate 4** show techniques for anchoring poly.

In many situations during high water, poly and sandbags placed in the wet must provide the emergency protection. Wet placement may also be required to replace or maintain

damaged poly or poly displaced by current action. **Plate 4** shows a typical section of levee covered by poly and sandbags in the wet. Sandbag anchors are formed at the bottom edge and ends of the poly by bunching the poly around a fistful of sand or rock and tying the sandbags to this fist-sized ball. Counterweights consisting of two or more sandbags connected by a length of ¼-inch rope are used to hold the center portion of the poly down. The number of counterweights will depend on the uniformity of the levee slope and current velocity. Placement of the poly consists of first casting out the poly sheet with the bottom weights and then adding counterweights to slowly sink the poly sheet into place. The poly, in most cases, will continue to move down slope until the bottom edge reaches the toe of the slope. Sufficient counterweights should be added to ensure that no air voids exist between the poly and the levee face and to keep the poly from flapping or being carried away in the current. For this reason, it is important to have enough counterweights prepared prior to the placement of the sheet.

The implementation of poly with sandbags can be overused or misused. For example, on well compacted clay embankments, in areas of relatively low velocities, use of poly would be excessive. Also, placement of poly on landward slopes to prevent seepage must not be done. It will only force seepage to another exit and may prove detrimental. A critical analysis of a situation should be made before poly and sandbags are used, with a view toward less waste and more efficient use of these materials and available manpower. However, if a situation is doubtful, poly should be used rather than risk a failure. Critical areas should have priority.

2. **Riprap** is a positive means of providing slope protection and has been used in a few cases where erosive forces were too large to effectively control by other means. Objections to using riprap when flood fighting are (1) its relatively high cost, (2) a large amount may be necessary to protect a given area, (3) availability, and (4) little control over its placement, particularly in the wet.
3. **Small groins** extending 10-feet or more into the channel were very effective in deflecting current away from the levees. Groins can be constructed using sandbags, snow fence, rock, compacted earth or any other substantial materials available. Preferably, groins should be placed in the dry and at locations where severe scour may be anticipated. Consideration of the hydraulic aspects of placing groins should be given because haphazard placement may be detrimental. Hydraulic technical assistance should be sought if doubts arise in the use of groins. Construction of groins during high water will be very difficult and results will generally be minimal. If something other than compacted fill is used, some form of anchorage or bonding should be provided; e.g., car bodies tied together or snow fence anchored to tree beyond the toe of levee.
4. **Log booms** have been used to protect levee slopes from debris or ice attack. Logs are cabled together and anchored with a dead man in the levee. The boom will float out in the current and, depending on the log size, will deflect floating objects.
5. **Miscellaneous Measures.** Several other methods of slope protection have been used. Straw bales pegged into the slope were successful against wave action, as was straw spread on the slope and overlain with snow fence.

4 Interior Drainage Treatment

4.1 General

High river stages often disrupt the normal drainage of sanitary and storm sewer systems, render sewage treatment plants inoperative, and cause back up in sewers and the discharge of untreated sewage directly into the river. When the river recedes, some of the sewage may be trapped in low-lying pockets to remain as a possible source of contamination. Hastily constructed dikes intended to keep out river waters may also seal off normal outlet channels for local runoff, creating large ponds on the landward side of the dikes, making the levees vulnerable from both sides. If the ponding is excessive, it may nullify the protection afforded by the dikes even if they are not overtopped. Sewers may also back up because of this ponding.

4.2 Preliminary Work

To arrive at a reasonable plan for interior drainage treatment, field personnel must obtain several items of information:

- a. Size of drainage area.
- b. Pumping capacity and/or ponding required. If data are not available, can be estimated by hydraulic engineering personnel.
- c. Basic plan for treatment.
- d. Storm and sanitary sewer and water line maps, if available.
- e. Location of sewer outfalls (abandoned or in use).
- f. Inventory of available local pumping facilities.
- g. Probable location of pumping equipment.
- h. Whether additional ditching is necessary to drain surface runoff to ponding and/or pump locations.
- i. Location of septic tanks and drain fields abandoned or in use.

4.3 Determination of Pumping Requirements

1. Storm Water and Seepage Computation.

Storm Water Runoff: Pumping Rate (gpm) = KAM

K is a constant, which can be determined from Table A, the contributing drainage area in acres is defined by A, and M is a factor if substantial ponding is available (**Table B**). If long duration flooding is expected, pumping provided should be above the "minimum pumping" capacities determined in this section. Note that the constant K from **Table A** reflects relatively minor rainfalls and damages from large rainfalls are still possible.

- a. **Ponding.** If substantial ponding areas are available, the required pumping can be reduced by a reduction of M in the formula "Pumping Rate (gpm) = KAM ". To determine a reduction in the M value, use the following formula and **Table B**.

$$X = (PA \times Ave. \text{ Depth} \times 100) / A$$

where PA = pond surface area in acres at maximum allowable pond elevation.

Ave. Depth = Average depth of ponding area in feet.

A = contributing drainage area in acres.

- b. **Seepage.** A seepage allowance of 1 to 2 gpm per lineal foot of levee should be added to the pumping rate determined from the above formula, if the foundation is relatively pervious. If the foundation consists of a thick clay layer, seepage will be negligible.

2. **Hypothetical Example.** Local civil defense officials are considering the emergency construction of approximately 3,000 lineal feet of levee, which will seal off the natural outlet for approximately 200 acres of local runoff from a small, non-storm sewered city on the Minnesota River where 1965 floodwaters exceeded flood stage for 15 days. It is estimated that 20 acres of ponding area with a maximum depth of 4 feet will be available. What pumping capacities can be recommended for the removal of surface runoff and seepage through the levee?

Assuming this city is in the northern part of area 3, select K values from **Table A**.

$$K \text{ minimum} = 30$$

$$K \text{ desirable} = 90$$

Assuming the average depth of the ponding area is $1/2$ of the maximum depth:

$$\text{Average depth} = 1/2 \times 4.0 = 2.0 \text{ feet}$$

$$X = \frac{20 \times 2.0 \times 100}{200} = 20.0$$

Select M from **Table B**

$$M = 0.9$$

Runoff pumping rate from 200 acres:

$$\text{"minimum" pumping} = 30 \times 200 \times 0.9 = 5,400 \text{ gpm}$$

$$\text{"desirable" pumping} = 90 \times 200 \times 0.9 = 16,200 \text{ gpm}$$

Seepage:

$$3,000 \text{ lineal feet} \times 1 \text{ gpm/foot} = 3,000 \text{ gpm}$$

Total Pumping:

$$\text{"Minimum" Pumping} = 5,400 + 3000 = 8,400 \text{ GPM}$$

$$\text{"Desirable" Pumping} = 16,200 + 3000 = 19,200 \text{ GPM}$$

3. Table A – Values of *K* for Computation of Pumping

<u>Area</u>	<u>"Minimum" K value*</u>	<u>"Desirable" K value*</u>
1. Red River and Souris River Basin	25 to 30	70 to 85
2. Headwaters Mississippi River Basin	25 to 30	70 to 90
3. Minnesota River Basin	30 to 35	90 to 100
4. Mississippi River Basin, Little Falls to St. Croix Basin at Prescott	30 to 35	85 to 95
5. Mississippi River Basin, Prescott to L/D No. 10	30 to 35	95 to 100
6. Wisconsin and Chippewa River Basin	30 to 35	85 to 100
7. Lake Superior Area	25 to 30	70 to 85

* The K value varies from the smaller value for the northern part of the designated area to the larger value for the southern part of the area. The "minimum" K value in the first column is for a 1/10 year frequency rain (10 events per year) varying from 0.5 to 0.7 inch in a 6-hour period and the "desirable" K value in the second column represents a 2-year frequency rain (1 event per 2 years) varying from 1.5 to 2.2 inches in a 6-hour period.

4. Table B – Values of *M* for Adjustment to Pumping Rate

<u>X</u>	<u>M</u>
0-10	1.0
10-20	0.9
20-25	0.8
25-30	0.7
30-35	0.6
35-40	0.5
40-45	0.4
45-50	0.3
50-55	0.2
55-60	0.1
Greater than 60	0.0

4.4 Pumps: Types, Sizes and Capacities

1. **Storm Sewer Pumps.** Table C indicates the size of pump needed to handle the full flow discharge from sewer pipes up to 24 inches in diameter. **Table D** shows sizes and capacities of agricultural type pumps that may be useful in ponding areas or in low areas adjacent to the flood barrier where a sump hole could be excavated. **Table E** lists full flow discharge capacities for clay sewer pipes laid on slopes of 0.001 and 0.005 feet per foot. Generally, the smaller pipes are laid on steeper slopes than are the larger pipes. **Table F** and **Table G** show sizes and capacities of Crisafulli and Flygt centrifugal pumps, respectively.
2. **Fire Engine Pumps.** The ordinary fire pumper has a 4-inch suction connection and a pumping capacity of about 750 gpm. Use only if absolutely necessary.
3. **Table C – Matching Pipe Size to Pump Size**

<u>Sewer Pipe Size</u>	<u>Probable Required Pump Size</u>
6-inch	2-inch
8-inch	2- to 3-inch
10-inch	3- to 4-inch
12-inch	4- to 6-inch
15-inch	6- to 8-inch
18-inch	6- to 10-inch
21-inch	8- to 10-inch
24-inch	10- to 12-inch

4. Table D – Typical Pump Discharge Capacities

16-inch Regular Pump @ 540 rpm

<u>Total Dynamic Head in Feet</u>	<u>Capacity Gallons per Minute</u>	<u>Brake Horsepower</u>
0	13,500	100
5	12,000	95
10	10,600	91
15	8,900	85
20	7,100	78
25	5,300	70
30	3,300	60
35	1,400	47
38.3	0	36.5

Table D -- Typical Pump Discharge Capacities – Continued

12-inch Regular Pump @ 540 rpm

Total Dynamic Head in Feet	Capacity Gallons per Minute	Brake Horsepower
0	5,525	42
5	5,100	40
10	4,600	38
15	3,900	35
20	2,900	30
24.8	0	15.6

5. Table E – Capacity of Clay Sewer Pipe

Pipe Size	---- S = 0.001 ----		---- S = 0.005 ----	
	<u>cfs</u>	<u>gpm</u>	<u>cfs</u>	<u>gpm</u>
6-inch	0.19	85	0.35	156
8-inch	0.35	156	0.76	340
10-inch	0.65	292	1.60	720
12-inch	1.20	540	2.50	1,120
15-inch	2.1	945	4.5	2,020
18-inch	3.4	1,520	7.3	3,260
21-inch	5.0	2,230	11.2	5,000
24-inch	8.2	3,660	15.2	6,800

6. Table F – Crisafulli Pumps -- Model CP 2-inch to 24-inch

Pump Size	----- 10-foot Head -----		
	<u>gpm</u>	<u>Elec. HP</u>	<u>Gas or Diesel HP</u>
2-inch	150	1	
4-inch	500	7.5	15
6-inch	1,000	10	20
8-inch	3,000	15	25
12-inch	5,000	25	40
16-inch	9,500	40	65
24-inch	25,000	75	140

Table F – Crisafulli Pumps -- Model CP 2-inch to 24-inch – Continued

----- 20-foot Head -----			
<u>Pump Size</u>	<u>gpm</u>	<u>Elec. HP</u>	<u>Gas or Diesel HP</u>
2-inch	130	1	
4-inch	490	10	20
6-inch	850	15	25
8-inch	2,450	20	35
12-inch	3,750	30	50
16-inch	8,000	45	85
24-inch	19,000	100	190

----- 30-foot Head -----			
<u>Pump Size</u>	<u>gpm</u>	<u>Elec. HP</u>	<u>Gas or Diesel HP</u>
2-inch	120	1	
4-inch	475	12	25
6-inch	795	20	35
8-inch	2,150	25	45
12-inch	3,450	35	70
16-inch	7,100	60	125
24-inch	16,600	125	250

NOTE: Use high head pumps for heads over 20 feet.

7. Table G -- Flygt Centrifugal Pumps

<u>Pump Size</u>	<u>Capacity*</u>	<u>Horsepower</u>
3-inch	90 - 150 gpm	1.3 - 2.0 HP
4-inch	100 - 250 gpm	2.7 - 3.5 HP
6-inch	1,150 gpm	30.0 HP
8-inch	2,300 gpm	29.0 HP
10-inch	3,300 gpm	62.0 HP

* (at 25-foot head)

- 8. Pump Discharge Piping.** The Crisafulli pumps are generally supplied with 50-foot lengths of butyl rubber hose. Care should be taken to prevent damage to the hose. Irrigation pipe or small diameter culverts can also serve as discharge piping. The outlet of a pump discharge line should extend riverward far enough off the toe of the levee so that discharges do not erode the levee slope. The discharge end should be tied down or otherwise fixed to prevent its movement. These pumps must not be operated on slopes greater than 20 degrees from horizontal.
- 9. Sanitary Sewage Pumping.** During high water, increased infiltration into sanitary sewers may necessitate increased pumping at the sewage treatment plant or at manholes at various locations to keep the system functioning. To estimate the quantity of sewage, allow 100 gallons per capita per day for sanitary sewage and an infiltration allowance of 15,000 gallons per mile of sewer per day. In some cases, it will be necessary to pump the entire amount of sewage, and in other cases only the added infiltration will have to be pumped to keep a system in operation.

Example: Estimate pumping capacity required at an emergency pumping station to be set up at the first manhole above the sewage treatment plant for a city of 5,000 population and approximately 30 miles of sewer (estimated from map of city). In this case, it is assumed that the treatment plant will not operate at all.

Computation:

$$\text{Sewage: } \frac{5000 \text{ persons} \times 100 \text{ gal / person / day}}{24 \text{ hrs / day} \times 60 \text{ minutes / hr}} = 347 \text{ GPM}$$

$$\text{Infiltration: } \frac{15000 \text{ gal / minute / day} \times 30 \text{ min}}{24 \text{ hrs / day} \times 60 \text{ minutes / hr}} = 312 \text{ GPM}$$

Thus, required pumping capacity: 659 GPM

From *Table G*, use one 6-inch or three 4-inch pumps

4.5 Metal Culverts

Pumping of ponded water is usually preferable to draining the water through a culvert since the tail water (drainage end of culvert) could increase in elevation to a point higher than the inlet, and water could back up into the area being protected. Installation of a flap gate at the outlet end may be desirable to minimize backup.

If a culvert is desired to pass water from a creek through a levee a computation of the drainage basin, by an engineer, is required to determine pipe size.

4.6 Preventing Backflow in Sewer Lines

Watertight sluice gates, or flap gates can be used to prevent backflow. Emergency stoppers may be constructed of lumber, sandbags, or other materials, using poly as a seal, preferably placed on the discharge end of the outfall pipe. *Plate 8* and *Plate 9* show examples of prefabricated pipe stoppers that can be placed in the pipe to block flows. *Plate 6* and *Plate 7* illustrate methods of sealing off the outlet openings of a manhole with standard materials that are normally available so that the manhole may be used as an emergency pumping station.

5 Flood Fight Problems

5.1 General

The problems that can arise during a flood fight are varied and innumerable. The problems covered below and in Interior Drainage Treatment are those that are considered most critical to the integrity of the flood barrier system. It would be impossible to enumerate all the problems, such as supplies, personnel, communication, etc., that field personnel must handle. The most valuable asset of field personnel under emergency conditions is their common sense. Many problems can be solved instantly and effortlessly through the application of good common sense and human relations. Problems, such as those below, can be identified early only if a well organized levee patrol system with a good communication system exists. Also, the problems are considered in the light that high water exists on the levee slopes.

5.2 Overtopping

Overtopping of a levee is the flowing of water over the levee crown. Since most emergency levees are of an urban nature, overtopping should be prevented at any cost. Overtopping will generally be caused by (1) unusual hydrologic phenomena, which cause a much higher stage than anticipated (i.e., heavy rainfall or an ice dam in the channel), (2) insufficient time in which to complete the flood barrier, or (3) unexpected settlement of the barrier. Generally, emergency barriers are constructed 2 feet above the current prediction. If the crest prediction is raised during construction, additional height must be added to the barrier. On an existing or completed barrier, increasing predictions or settlement will call for some form of capping. Capping should be done with earth fill or sandbags using normal construction procedures.

5.3 Seepage

Seepage is percolation of water through or under a levee and generally first appears at the landside toe. Seepage through the levee is applicable only to a relatively pervious section. Seepage, as such, is generally not a problem unless (1) the landward levee slope becomes saturated over a large area, (2) seepage water is carrying material from the levee, or (3) pumping capacity is exceeded. Seepage that causes severe sand boils and piping is covered below. Seepage is almost impossible to eliminate and any attempt to do so may create a much more severe condition. Pumping of seepage should be held to a minimum, based on the maximum ponding elevation that can be tolerated without damages. Several levees were endangered during the 1965 and 1969 floods by attempts to keep low areas pumped dry, and additional time and effort were expended in controlling sand boils caused by pumping. Therefore, seepage should be permitted if no apparent ill effects are observed and if adequate pumping capacity is available. If seepage causes saturation and sloughing of the landward slope, it should be flattened to a 1V on 4H or flatter. Material for flattening should be at least as pervious as the embankment material.

5.4 Sand Boils

1. **Description.** A sand boil is the rupture of the top foundation stratum landward of a levee caused by excess hydrostatic head in the substratum. Even when a levee is properly constructed and of such mass to resist the destructive action of flood water, water may seep through a sand or gravel stratum under the levee and break through the ground surface on the landside in the form of bubbling springs. When such a seep occurs, a stream of water bursts through the ground surface carrying with it sand or silt that is distributed around the hole in the shape of a cone. Depending on the magnitude of pressure and the size of the boil, it may eventually discharge relatively clear water or it may continue to carry quantities of sand and silt. Sand boils usually occur within 10 to 300 feet from the landside toe of the levee and, in some instances, have occurred up to 1,000 feet away.
2. **Destructive Action.** Sand boils can produce three distinctly different effects on a levee, depending on the condition of flow under the levee.
 - a. **Piping Flow.** Piping is the active erosion of subsurface material as a result of substratum pressure and concentration of seepage in the localized channels. The flow breaks out at the landside toe in the form of one or more large sand boils. Unless checked, this flow causes the development of a cavern under the levee, resulting in the subsidence of the levee and possible overtopping. This case can be easily recognized by the slumping of the levee crown.
 - b. **Non Piping Flow.** In this case, the water flows under pressure beneath the levee without following a defined path, as in the case above. This flow results in one or more boils outcropping at or near the landside toe. The flow from these boils tends to undercut and unravel the landside toe, resulting in sloughing of the landward slope.
 - c. **Saturating Flow.** In this case, numerous small boils, many of which are scarcely noticeable, outcrop at or near the landside toe. While no boil may appear to be dangerous by itself, the group of boils may cause saturation and flotation ("quickness") of the soil. This can reduce the shear strength of the material at the levee toe to such an extent that failure of the slope through sliding may result.
3. **Combating Sand Boils.** All sand boils should be watched closely, especially those within 100 feet of the toe of the levee. All boils should be conspicuously marked with flagging so that patrols can locate them without difficulty and observe changes in their condition. A sand boil that discharges clear water in a steady flow is usually not dangerous to the safety of the levee. However, if the flow of water increases and the sand boil begins to discharge material, corrective action should be undertaken immediately. The accepted method of treating sand boils is to construct a ring of sandbags around the boil, building up a head of water within the ring sufficient to check the velocity of flow, thereby preventing further movement of sand and silt. See *Plate 5* for technique in ringing a boil. Actual conditions at each sand boil will determine the exact dimensions of the boil and the flow of water from it.

In general, the following considerations should control construction of the sandbag ring: (1) the base width of the sandbag section should be no less than 1-1/2 times the contemplated height, (2) weak soils near the boil be included within the ring, thereby preventing a break through later, and (3) the ring should be sufficient size to permit

sacking operations to keep ahead of the flow of water. The height of the ring should only be that necessary to stop movement of soil and not so high as to completely eliminate seepage. The practice of carrying the ring to the river elevation is not necessary and may be dangerous in high stages. If seepage flow is completely stopped, a new boil will likely develop beyond the ring. This boil could erupt suddenly and cause considerable damage. Where many boils are found to exist in a given area, a ring levee of sandbags should be constructed around the entire area, and, if necessary, water should be pumped into the area to provide sufficient weight to counterbalance the upward pressure.

5.5 Erosion

Erosion of the riverside slope is one of the most severe problems that will be encountered during a flood fight. Emergency operations to control erosion have been discussed under the section titled, Scour Protection for Emergency Levees.

5.6 Storm and Sanitary Sewers

- 1. Problems.** Existing sewers in the protected area may cause problems because of seepage into the lines, leakage through blocked outlets to the river, manhole pumps not spread throughout the sewer system, or old or abandoned sewer locations that were not found during preflood preparations. Any of these conditions can cause high pressures in parts of the sewer system and lead to collapse of the lines at weak points and blowing off of manhole covers.
- 2. Solutions.** During the flood fight, continued surveillance of possible sewer problems is necessary. If the water level in a manhole approaches the top, additional pumps in manholes may alleviate the problem. In sanitary sewers, additional pumping may be required at various locations in the system to provide continued service to the homes in the protected area. When pumps are not available, manholes may have to be ringed with sandbags or by some other method that allows the water to head up above the top of the manhole. To eliminate the problem of disposing of this leakage from manholes, the ring dike would have to be raised above the river water surface elevation. Doing so creates high pressures on the sewer and should not be done. As with sand boils, it is best to ring the manhole part way to reduce the head and dispose of any leakage that occurs. Directly weighing down manhole covers with sandbags or other items is not recommended where high heads are possible. A 10-foot head on a manhole cover 2 feet in diameter would exert a force of 2,060 pounds. Thus, a counterweight of more than one ton would have to be placed directly on the cover.

5.7 Closures

Closures consist of gaps in the flood barrier system that are to be left open until flood stages reach a critical elevation. Typical examples of closures include roadways and railroad tracks where traffic is allowed to continue to cross the flood barrier until the water level reaches an elevation where the risk of flooding becomes unacceptable. The size and number of closures should be kept to an absolute minimum. Although closures can typically be constructed fairly quickly, unanticipated problems occurring at the critical time when closures are to be placed

could require resources to be reallocated elsewhere. This could result in a hole in the line of protection.

5.8 Causes of Levee Failure

In addition to the problems covered above, the following conditions could contribute to failure:

- Joining of a levee to a solid wall, such as concrete or piling.
- Structures projecting from the riverside of levee.
- A utility line crossing or a drain pipe through the fill.
- Tops of stoplogs on roads or railroad tracks at a lower elevation than the levee.
- Relying on railroad embankment as levee. Material comprising the railroad embankment may not be suitable as levee fill. Furthermore, the railroad embankment section often has a narrow top width and steep side slopes.
- Allowing pump discharge lines to outlet on the riverward levee slope. When discharge lines are allowed to outlet on the levee slope, severe erosion can occur thus threatening the levee stability. Insure that outlets for pump discharge lines are placed riverward of the levee toe and appropriately anchored to prevent movement.

6 *Recommended Techniques for Flood Fighting Activities*

- PLATE 1: Recommended Method for Sandbag Levee Construction
- PLATE 2: Recommended Method for Flashboard or Box Levees
- PLATE 3: Recommended Method for Placement of Polyethylene Sheeting on Temporary Levees (when placed in the dry)
- PLATE 4: Recommended Method for Placement of Polyethylene Sheeting on Temporary Levees (when placed in the wet)
- PLATE 5: Recommended Method for Ringing Sand Boils
- PLATE 6: Recommended Method for Adapting Manhole for Pumping, Method 1
- PLATE 7: Recommended Method for Adapting Manhole for Pumping, Method 2
- PLATE 8: Recommended Method for Plugging Pipes, Method 1
- PLATE 9: Recommended Method for Plugging Pipes, Method 2

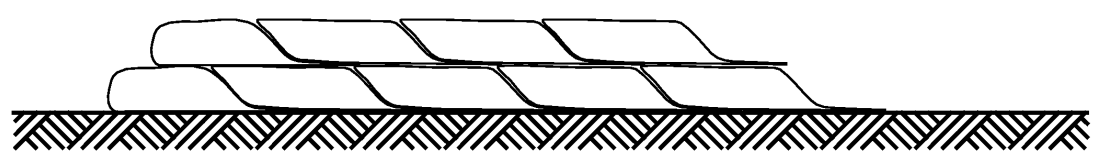
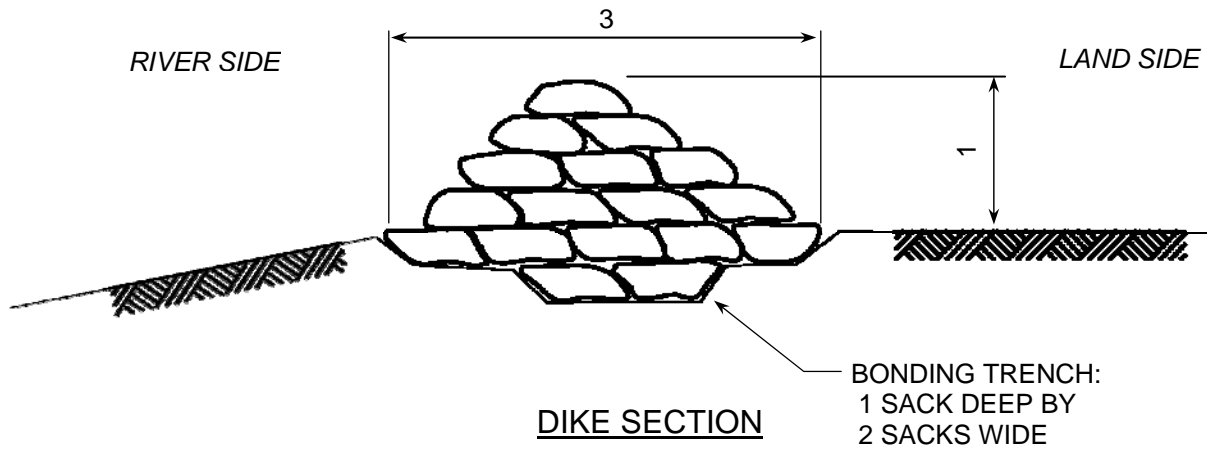

METHOD OF LAPPING SACKS

DIKE HEIGHT	NUMBER OF SAND BAGS REQUIRED FOR LENGTH OF DIKE									
	50 FT	100 FT	175 FT	200 FT	250 FT	300 FT	350 FT	400 FT	450 FT	500 FT
1 FT	250	500	750	1000	1250	1500	1750	2000	2250	2500
2 FT	850	1700	2550	3400	4250	5100	5950	6800	7650	8500
3 FT	1800	3600	5400	7200	9000	10800	12600	14400	16200	18000
4 FT	3100	6200	9300	12400	15500	18600	21700	24800	27900	31000

NOTES:

1. START UPSTREAM.
2. STRIP SOD BEFORE LAYING.
3. ALTERNATE DIRECTION OF SACKS WITH BOTTOM LAYER PARALLEL TO FLOW.
4. NEXT LAYER PERPENDICULAR TO FLOW, ETC.
5. LAP UNFILLED PORTION UNDER NEXT SACK.
6. TYING OR SEWING SACKS NOT NECESSARY.
7. TAMP THOROUGHLY IN PLACE, SACKS SHOULD BE APPROXIMATELY ½-FULL OF SAND.



**US Army Corps
of Engineers**[®]
St. Paul District

EMERGENCY FLOOD CONTROL ACTIVITIES
RECOMMENDED METHOD FOR
SANDBAG LEVEE CONSTRUCTION

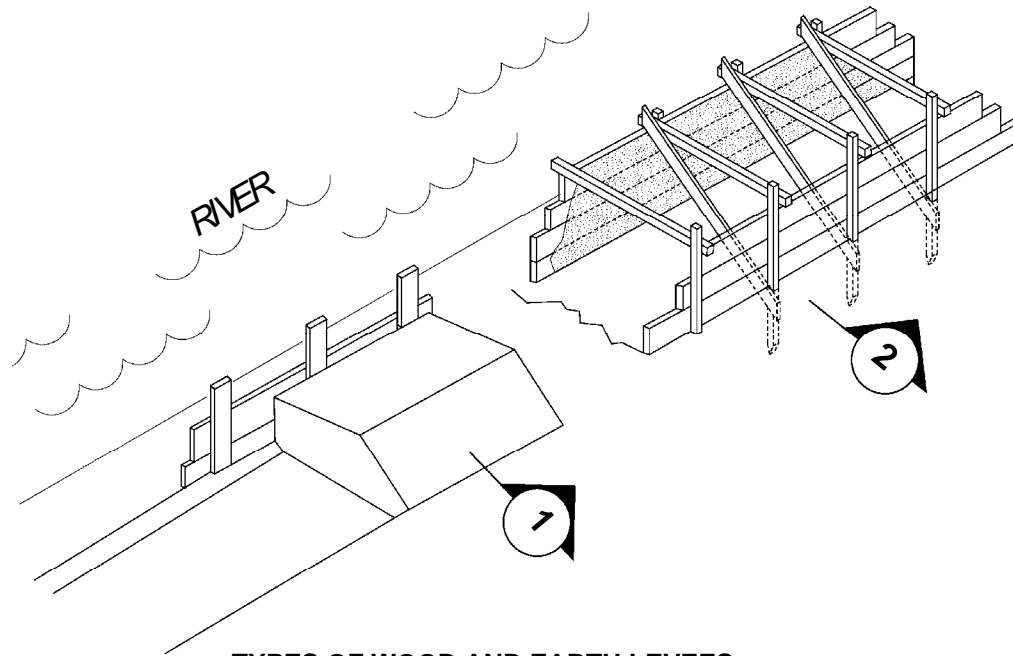

TYPES OF WOOD AND EARTH LEVEES

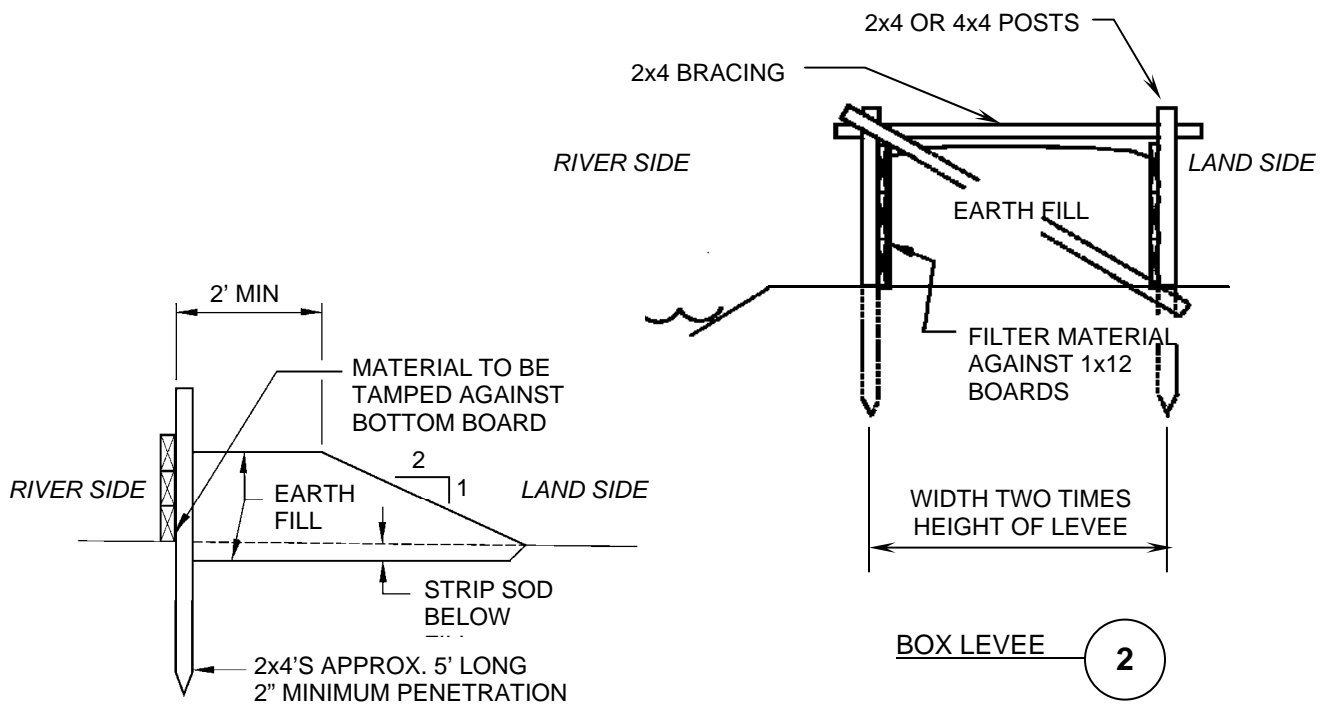

FLASH BOARD LEVEE 1

BOX LEVEE 2



**US Army Corps
of Engineers**
St. Paul District

**EMERGENCY FLOOD CONTROL ACTIVITIES
RECOMMENDED METHOD FOR
FLASH BOARD OR BOX LEVEES**

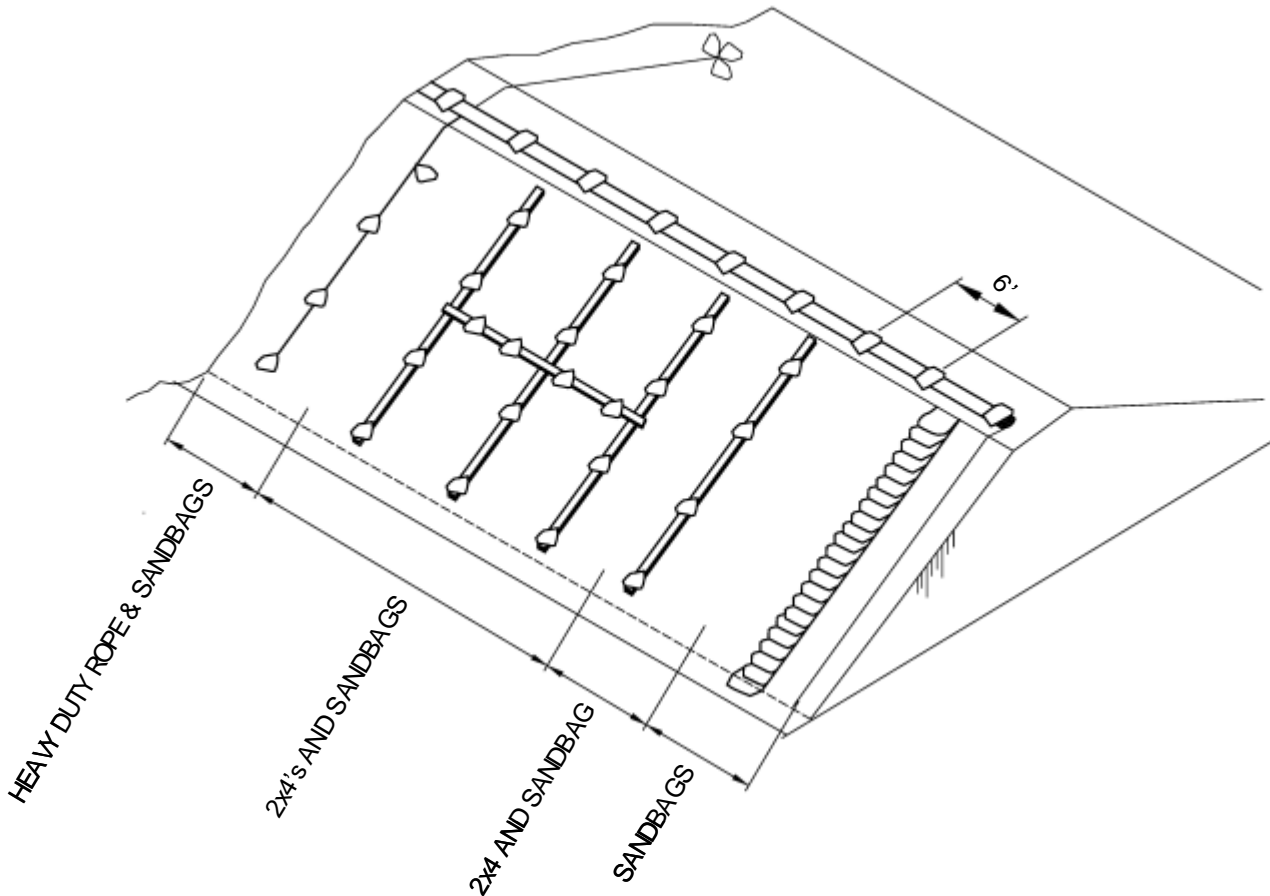

VARIOUS METHODS OF ANCHORING POLYETHYLENE

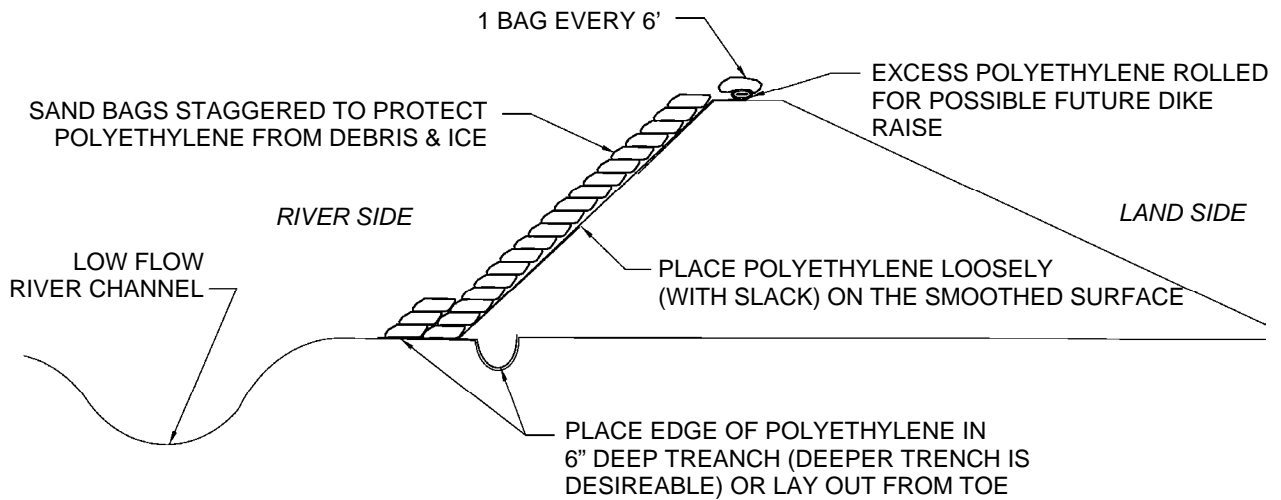

SECTION

RECOMMENDED POLYETHYLENE

- 1st - 6 MIL BLACK
- 2nd - 6 MIL CLEAR
- 3rd - 4 MIL BLACK
- 4th - 4 MIL CLEAR
- 5th - 2 MIL BLACK OR CLEAR
USE AS A LAST RESORT



**US Army Corps
of Engineers**
St. Paul District

EMERGENCY FLOOD CONTROL ACTIVITIES

RECOMMENDED METHOD FOR
PLACEMENT OF POLYETHYLENE
SHEETING ON TEMPORARY LEVEES
(WHEN PLACED IN THE DRY)

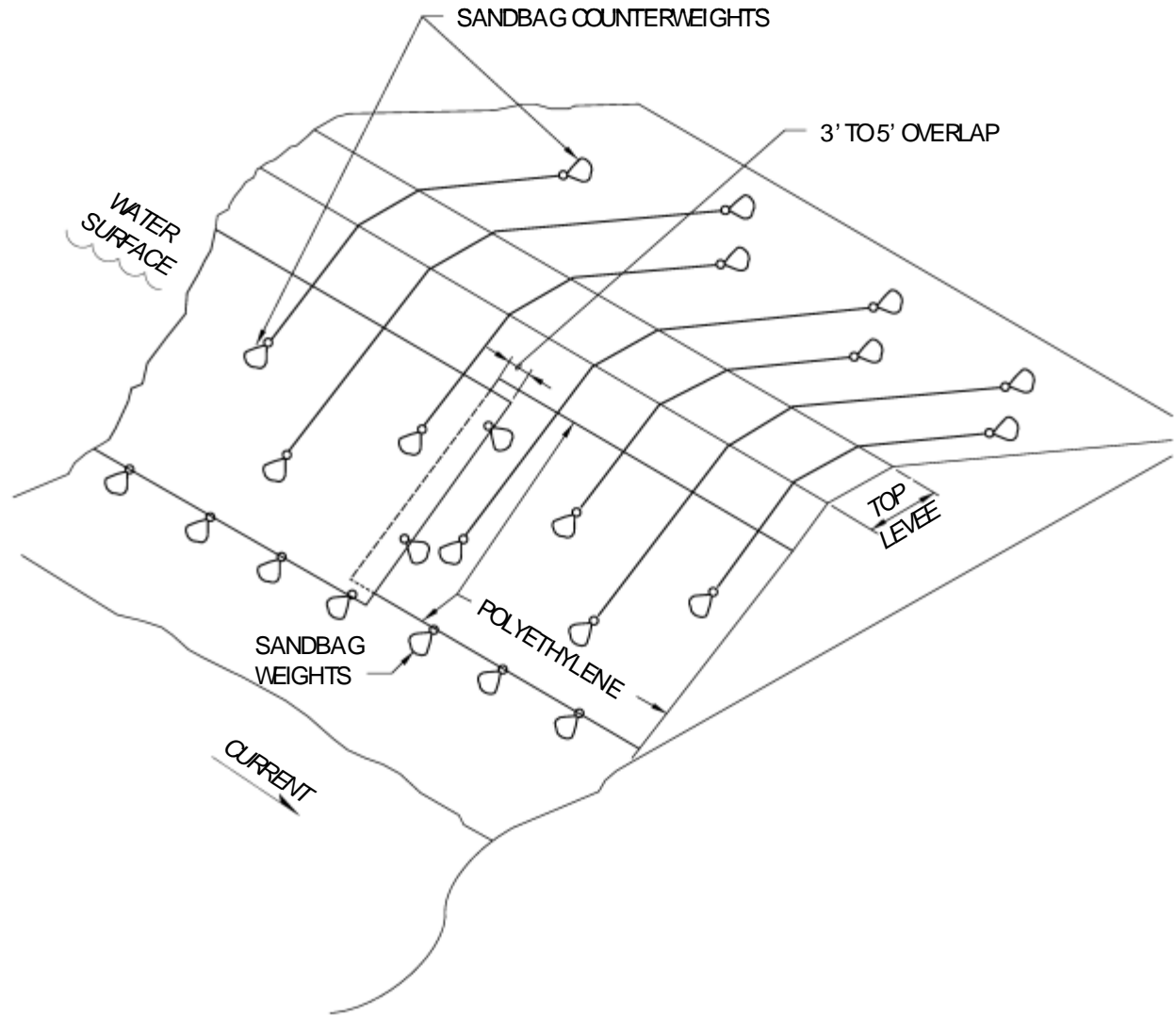

**US Army Corps
of Engineers**®
St. Paul District

EMERGENCY FLOOD CONTROL ACTIVITIES
RECOMMENDED METHOD FOR
PLACEMENT OF POLYETHYLENE
SHEETING ON TEMPORARY LEVEES
(WHEN PLACED IN THE WET)

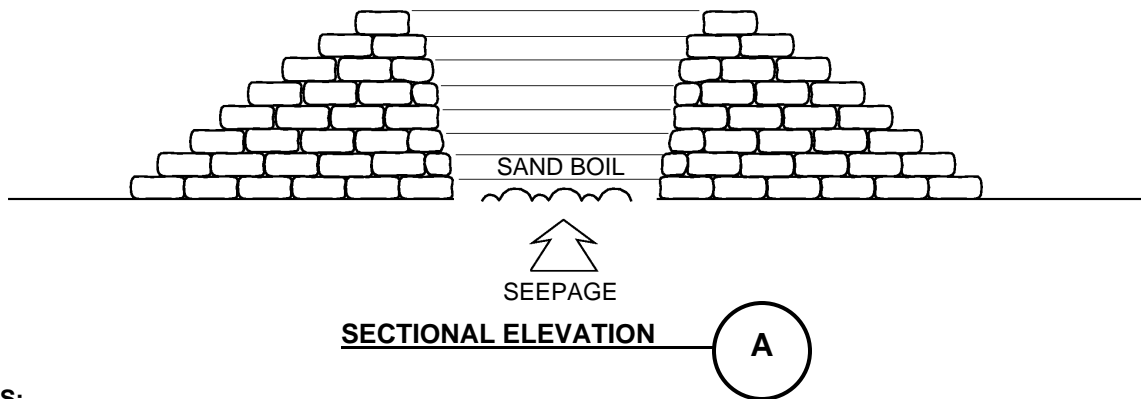
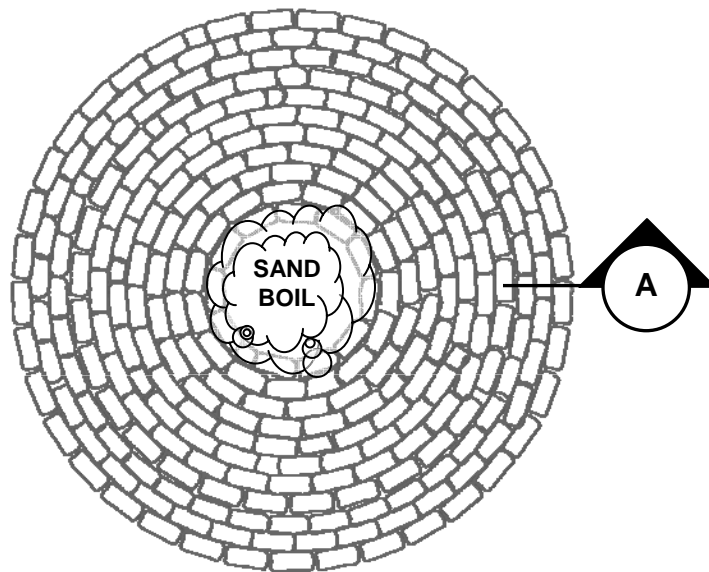
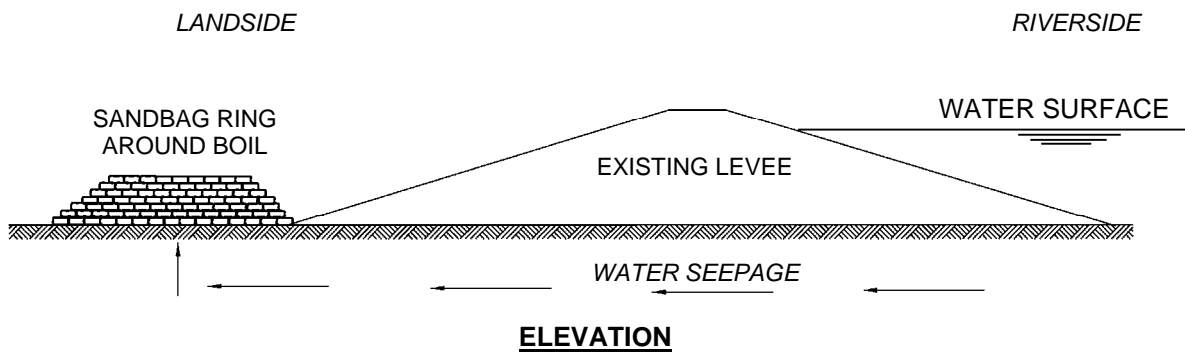

NOTES:

1. BOTTOM WIDTH TO BE NO LESS THAN 1-1/2 TIMES THE HEIGHT. TIE INTO LEVEE IF BOIL IS NEAR TOE.
2. ENTIRE BASE TO BE CLEARED AND SCARIFIED.
3. LOOSE EARTH TO BE USED BETWEEN ALL SACKS.
4. ALL JOINTS TO BE STAGGERED.



**US Army Corps
of Engineers**
St. Paul District

EMERGENCY FLOOD CONTROL ACTIVITIES
RECOMMENDED METHOD FOR
RINGING SAND BOILS

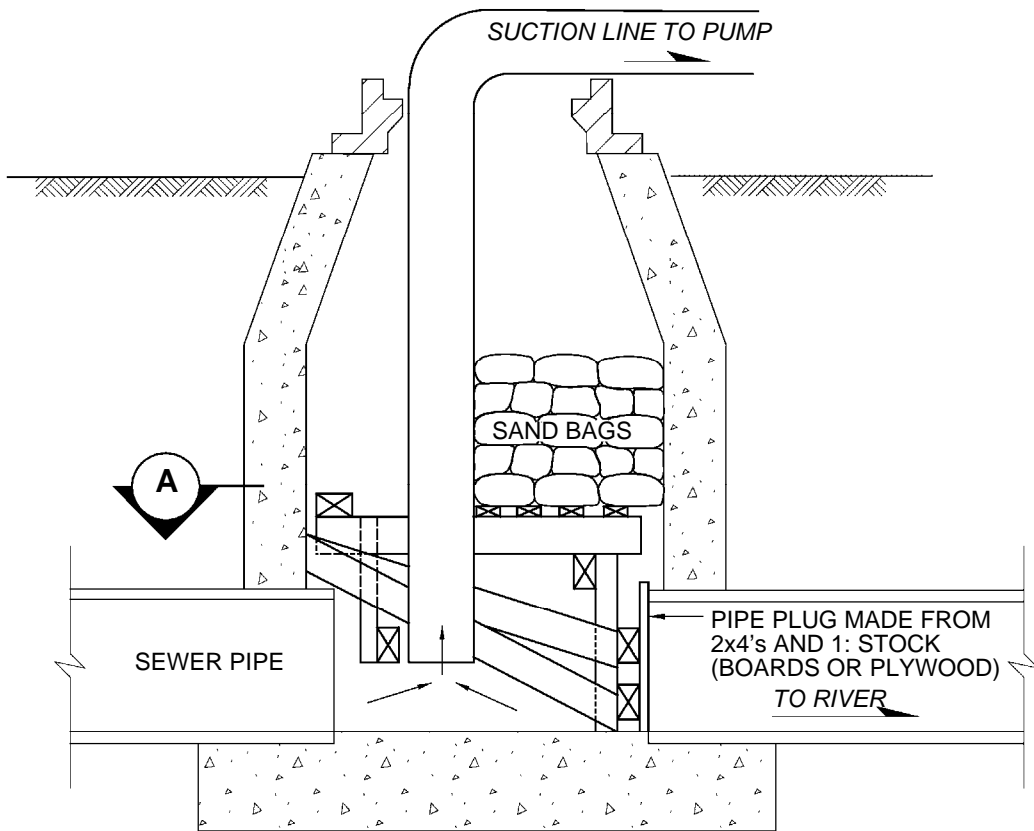

**ADAPTING MANHOLE FOR PUMPING
DURING FLOOD EMERGENCY**

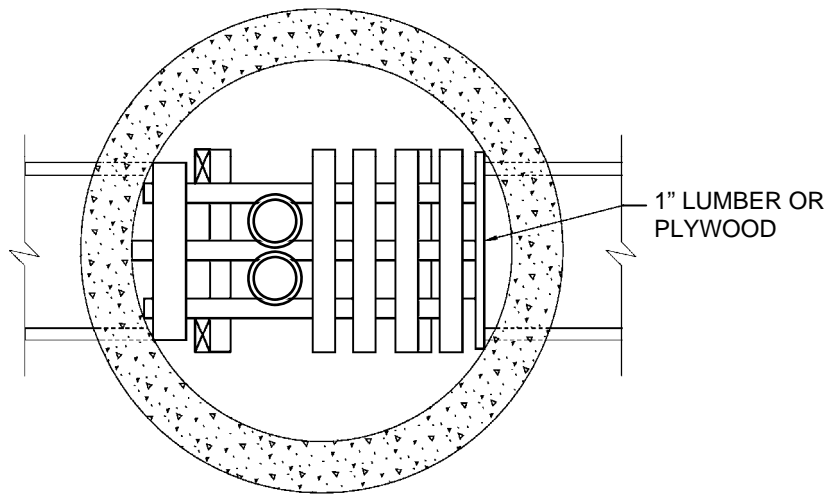

SECTION A



**US Army Corps
of Engineers**
St. Paul District

**EMERGENCY FLOOD CONTROL ACTIVITIES
RECOMMENDED METHOD FOR
ADAPTING MANHOLE FOR PUMPING
(METHOD 1)**

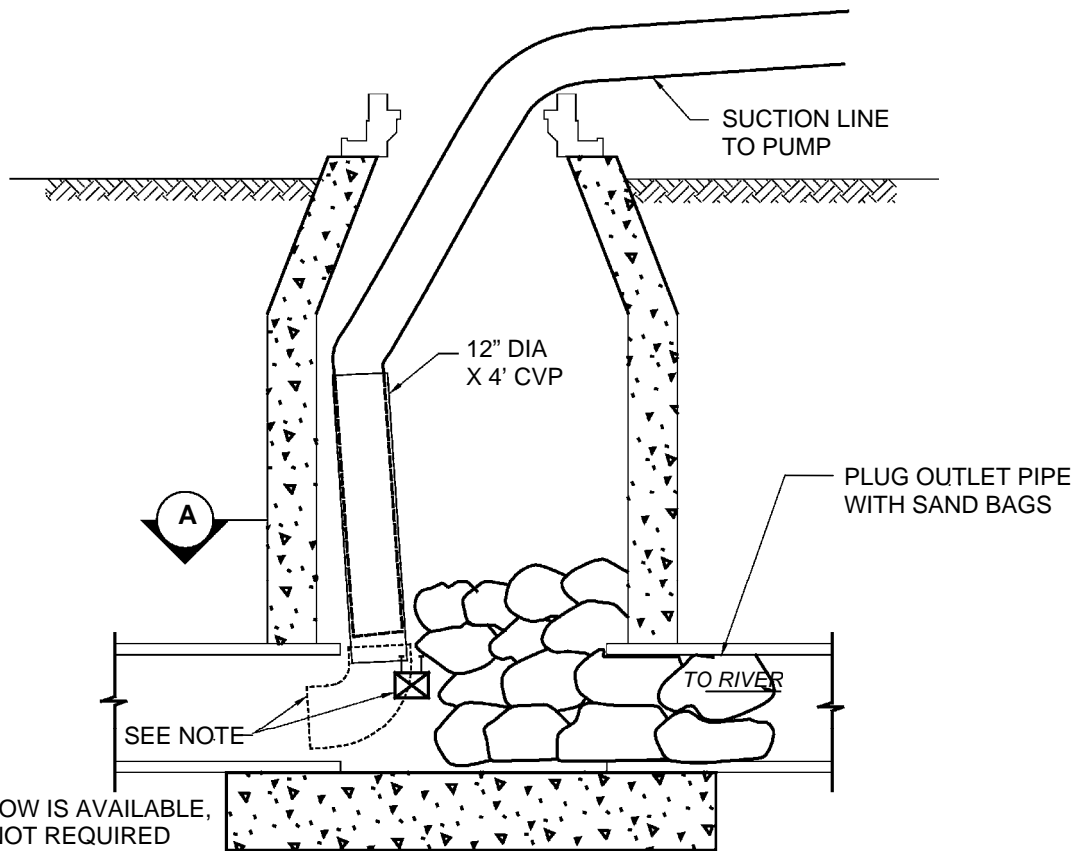

**ADAPTING MANHOLE FOR PUMPING
DURING FLOOD EMERGENCY**

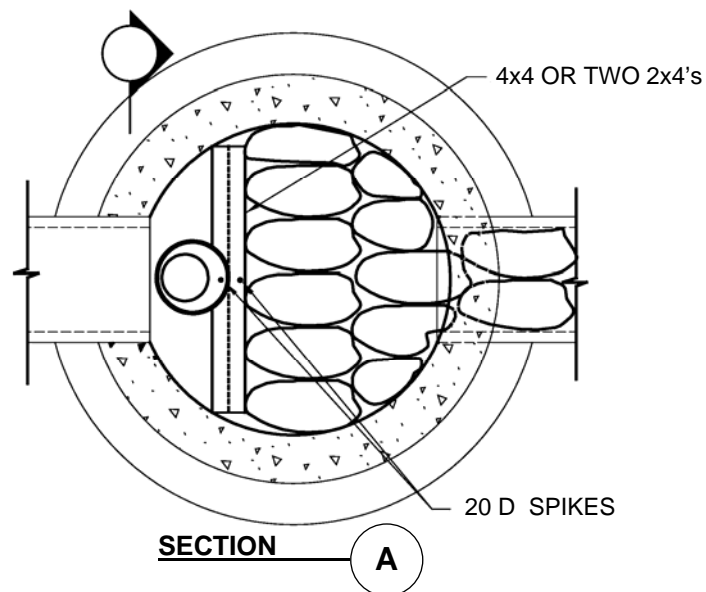

**US Army Corps
of Engineers**[®]
St. Paul District

EMERGENCY FLOOD CONTROL ACTIVITIES
RECOMMENDED METHOD FOR
ADAPTING MANHOLE FOR PUMPING
(METHOD 2)

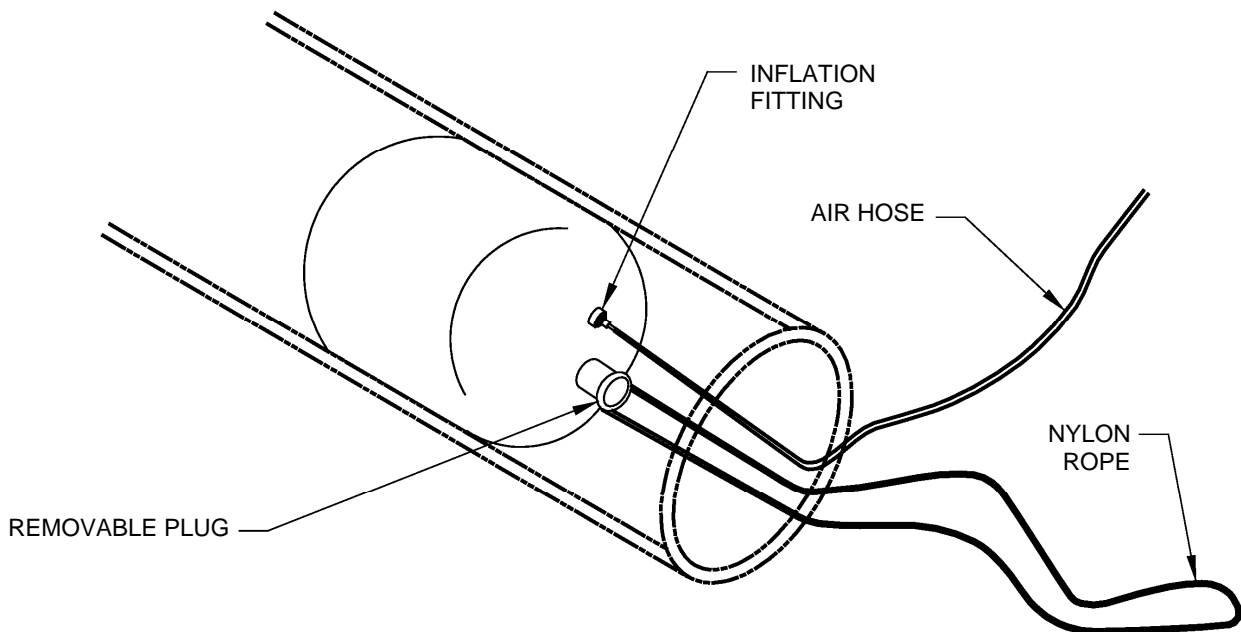
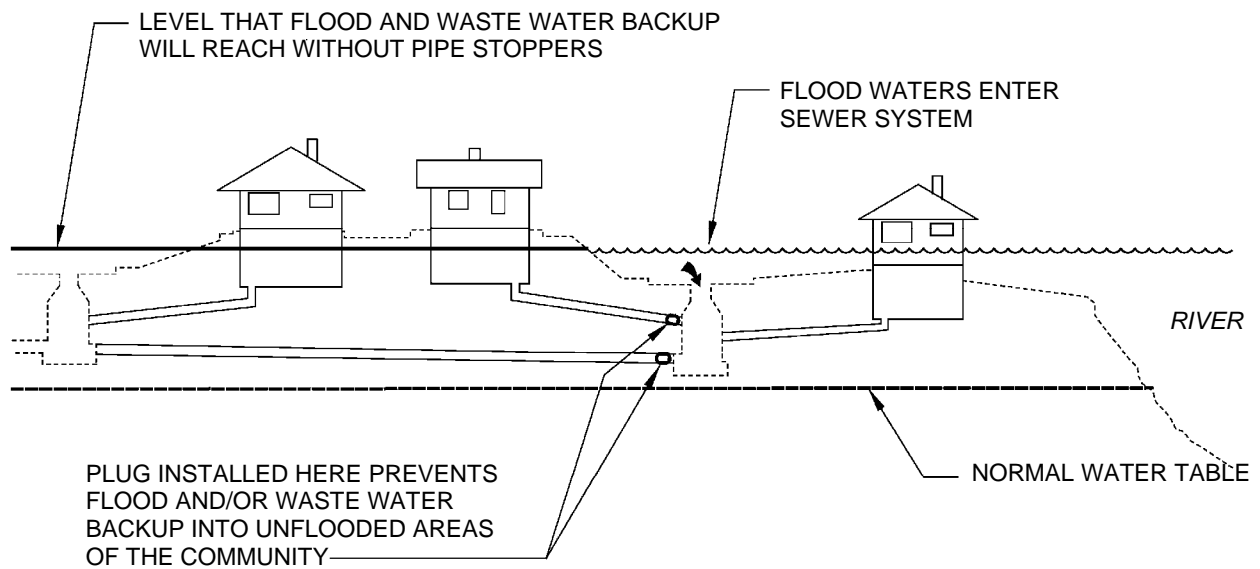

CHERNE INDUSTRIAL PIPE STOPPERS

IMMEDIATE DELIVERY OF PIPE PLUGS RANGING IN SIZE FROM 6-INCHES THROUGH 53-INCHES CAN BE MADE LOCALLY. THE CHERNE "MUNI-BALL PLUG" FITS STANDARD PIPE SIZES FROM 6-INCHES THROUGH 24-INCHES. PRICES RANGE FROM \$43.20 THROUGH \$780.00 FOR A WIDE RANGE OF PIPE STOPPERS WITH SPECIAL CONFIGURATIONS AVAILABLE, SUCH AS BY-PASS VALVE FOR SEWAGE PUMP CONNECTION TO RELIEVE BACK-PRESSURE.

CHERNE INDUSTRIES
 5700 LINCOLN DRIVE
 MINNEAPOLIS, MN 55436
 PHONE: 800-843-7584
 FAX: 800-843-7585
<http://www.cherneind.com/>



**US Army Corps
 of Engineers**
 St. Paul District

EMERGENCY FLOOD CONTROL ACTIVITIES
 RECOMMENDED METHOD FOR
 PLUGGING PIPES
 (METHOD 1)

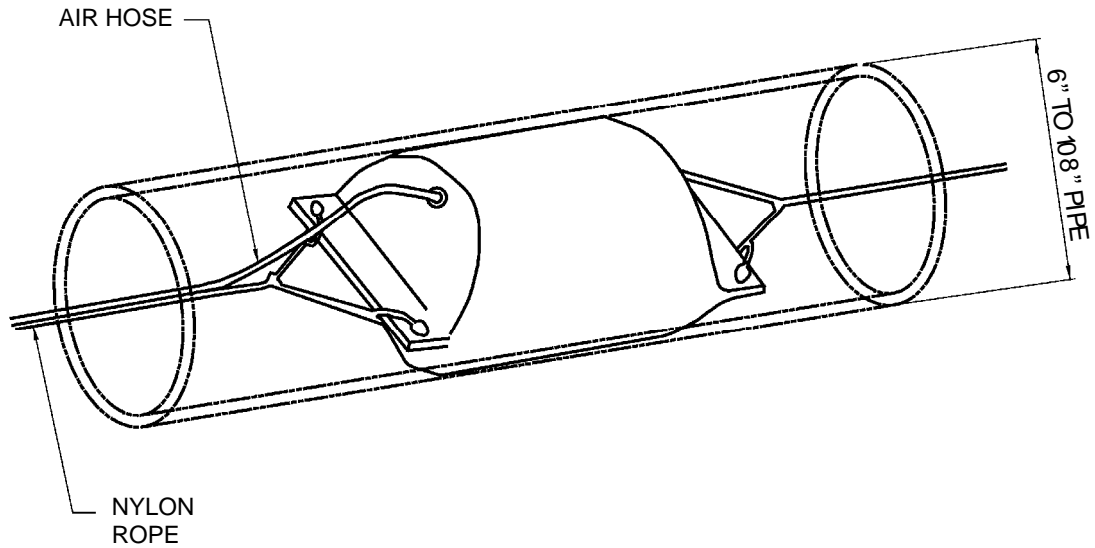

N.B. PRODUCTS PIPE STOPPER

N.B. PRODUCTS, INC. MANUFACTURES A RUBBERIZED PIPE STOPPER IN ALL STANDARD PIPE SIZES FROM 6" TO 108". THE COST FOR THESE DEVICES RANGES FROM \$20.00 TO \$3,000. ADDITIONAL EQUIPMENT REQUIRED FOR INSTALLING THE PIPE STOPPER ARE AN AIR HOSE KIT, AIR HOSE, AND NYLON ROPE. A TWO-WEEK SHIPPING PERIOD IS REQUIRED. MANUFACTURING LEAD TIME IS REQUIRED FOR SIZES OVER 60". ORDERS FOR THESE UNITS CAN BE PLACED TO:

N.B. PRODUCTS, INC.
ATTN: C.S. MCNULTY
35 BEULAH ROAD
NEW BRITAIN, PENNSYLVANIA 18901
215-345-1879



**US Army Corps
of Engineers**®
St. Paul District

EMERGENCY FLOOD CONTROL ACTIVITIES
RECOMMENDED METHOD FOR
PLUGGING PIPES
(METHOD 2)



**US Army Corps
of Engineers**®
St. Paul District

NOTES